

# M2582, M5081, and M5180 Series Electromechanical and Pneumatic, Fuel Gas Shut-off Valves Installation and Operation Instructions

M-7980N  
Revised 2015-01-06  
Section 55  
00-02-0206



Please read the following instructions before installing. A visual inspection of this product for damage during shipping is recommended before mounting. It is your responsibility to have a qualified person install the unit and make sure installation conforms with NEC and local codes.

## GENERAL INFORMATION

### WARNING

BEFORE BEGINNING INSTALLATION OF THIS MURPHY PRODUCT

- ✓ Disconnect all electrical power to the machine.
- ✓ Make sure the machine cannot operate during installation.
- ✓ Follow all safety warnings of the machine manufacturer.
- ✓ Read and follow all installation instructions.



Model M5081



Approved\*

### M2582 and M5081 Series

#### Tripping Power From Engine Ignition System or Battery (Models available for magneto, CD ignition or 12/24 V battery)

These fuel shut-off valves are semi-automatic devices for shutdown of natural gas fueled engines. The standard valve opens by manual operation of the reset handle. A latch in the upper body of the valve will set and hold the valve open. At this point no electric power is used. The electromagnetic coil is de-energized, the snap-switch(es) is SET.

If a SWICHGAGE® contact closes, a circuit is completed from power through the snap-switch and coil. Now energized, the electromagnet trips the latch, (latch can be tripped manually), the valve closes, and the snap-switch resets. Power switches from the coil circuit to your choice of an open line, an electrical ground, or an alarm. After tripping, the vent seal opens, and on the M50 models, the open/close indicator (green button) retracts to indicate that the valve is closed.

Valve body is sandcast aluminum. Optional cast steel for M5081 models.

### M2582-P and M5180-P

#### MURPHY-NUMATIC™ Pneumatic Version for Pressure

The M2582-P and M5180 pneumatically controlled valves can operate from pressure, and are designed to open and close automatically or semi-automatically (the supply can be air, oil or gas).

**NOTE:** If using oil as a pressure source, use a lightweight oil.

These valves will open on rising control pressure and close on decreasing control pressure. M2582-P and M5180-P automatically open at 2 psi (14 kPa) [0.14 bar] and fully open at 3 psi (21 kPa) [0.21 bar].

All models include a built-in lever to aid in opening the valve manually. The M2582-P can be manually opened against inlet pressure of 80 psi (552 kPa) [5.52 bar]. The M5180-P valve can be opened against inlet pressure of 100 psi (689 kPa) [6.89 bar].

Standard models include an escape vent for gas trapped forward in the line after shut-off.

### M5081FS

#### Normally Energized Circuit

The M5081FS is manually opened, electrically latched open and tripped by interrupting the coil power circuit.

#### Magnetic Switch Adapter

As ignition systems wear from usage, their power output becomes less and less. Ignition may not have the capacity to reliably trip the Fuel Valve. Therefore, the use of a Magnetic Switch Adapter for CD ignition systems is recommended. The Magnetic Switch Adapter is a device that stores energy from the CD ignition to trip the Fuel Valve. Three models are available:

65700053 (was 65020126): For use with negative ground ignitions up to 240 VDC.

65700054 (was 65020127): For use with positive ground ignitions up to 450 VDC.

65700055 (was 65020155): For use with negative ground ignitions up to 450 VDC.

#### 100 ohm, 2 watt Resistor

For Capacitor Discharge Ignitions that are specified to be grounded when the valve closes, and a Magnetic Switch Adapter is in use. The resistor must be connected in the system to prevent damage to the snap-switches in the fuel shut-off valve (see typical wiring diagrams).

#### Diode Package

The Murphy diode package (65010065) is designed to allow the fuel shut-off valve to be used with dual Magneto Ignition systems.

**NOTE:** All aluminum versions of the M5081 Series Fuel Valve carry Canadian Registration Number OC1476.2.

\* M5081 model is CSA approved for Class 1, Division 1, Groups C and D. See Specifications on page 12.

**M2582 Series**

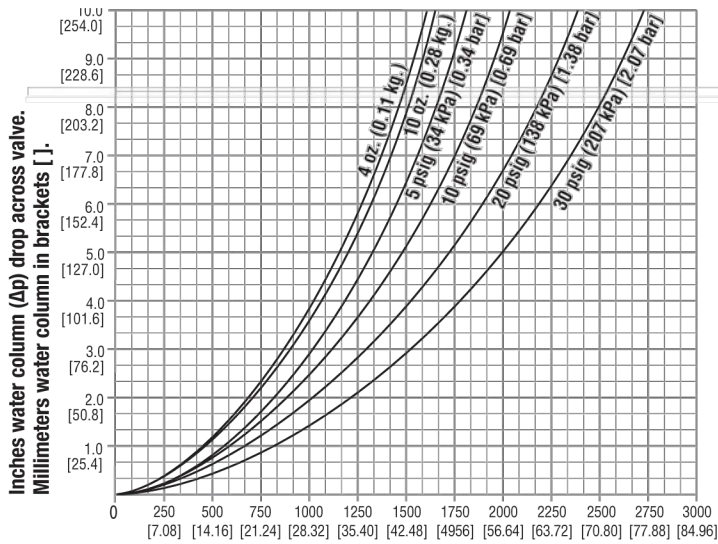

**M5081 and M5180 Series**

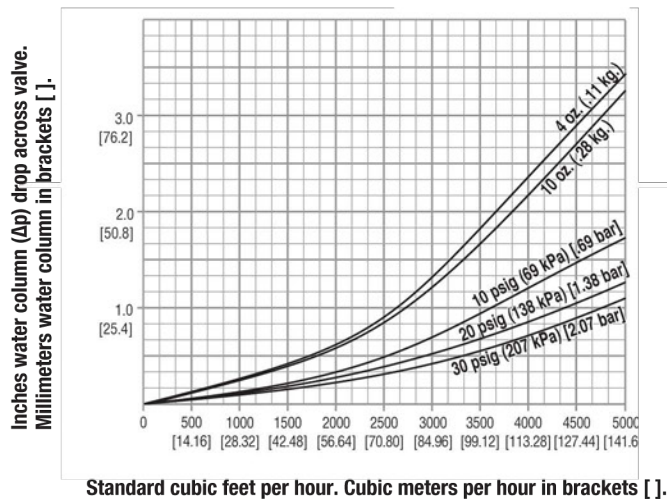

**Understanding the Basic Operation of the Fuel Shut-off Valve**

The valve below is shown in the run (open) position. Pressure is equalized, seat (B) is open, allowing the fuel to flow. When valve is in the tripped position (closed), seat closes (C).

The vent (D) opens to relieve trapped downstream fuel to vent to a non-hazardous area.

**TYPICAL MODEL (M5081) SHOWN**

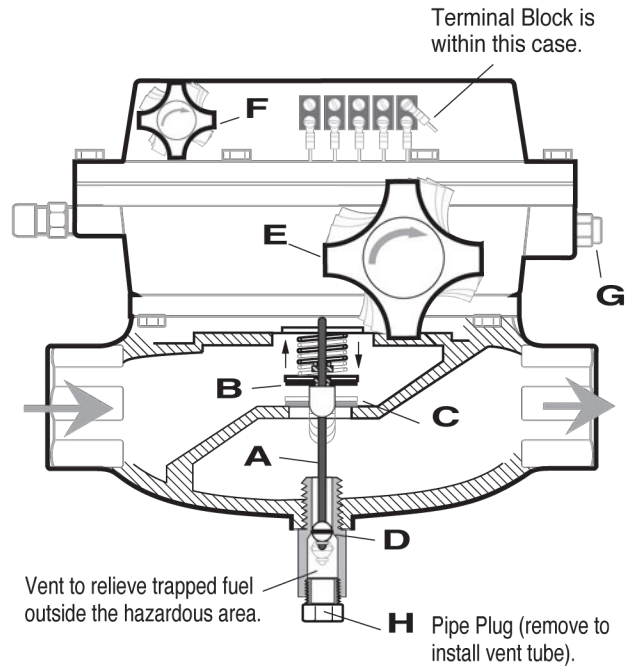

- A. Main Stem
- B. Pressure Disc/seal (in run/open)
- C. Pressure Disc/seal (in trip/closed)
- D. Vent Seal Gland
- E. Reset Knob (latches valve open)
- F. Manual Trip Knob (not available for M5081FS)
- G. Indicator Button (out with valve open)
- H. Pipe Plug

**NOTE:** If the vent-after-tripping feature is not used, remove O-ring (D), to avoid condensation accumulation that can hamper trip action.

**Be sure** to replace Pipe Plug (H) and to clean vent periodically.

# DIMENSIONS



**CAUTION:** THE ARROW ON THE SIDE OF THE FUEL VALVE **MUST** POINT TO THE CORRECT DIRECTION OF THE FLOW, FROM FUEL SOURCE TO THE ENGINE. APPLY PIPE DOPE **ONLY** TO FUEL PIPE, **NOT** TO THE FUEL VALVE.

## M2582

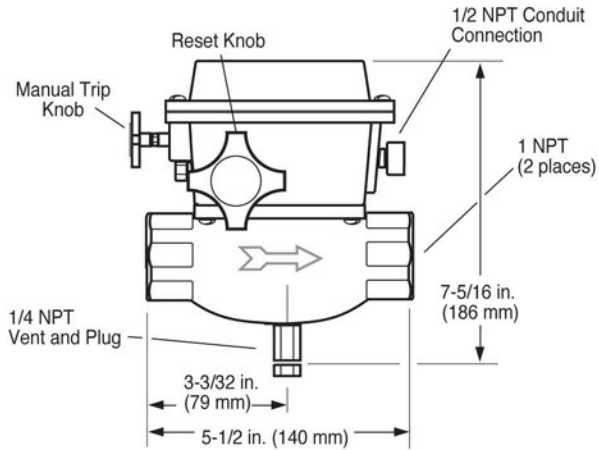

## M2582-P

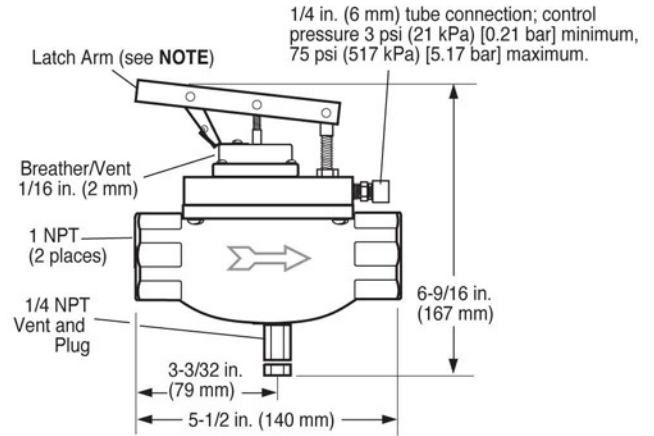

**NOTE:** Thumb operated opening latch (2.5 psi [17 kPa] [0.17 bar] required to release cocking latch)

## M5180-P

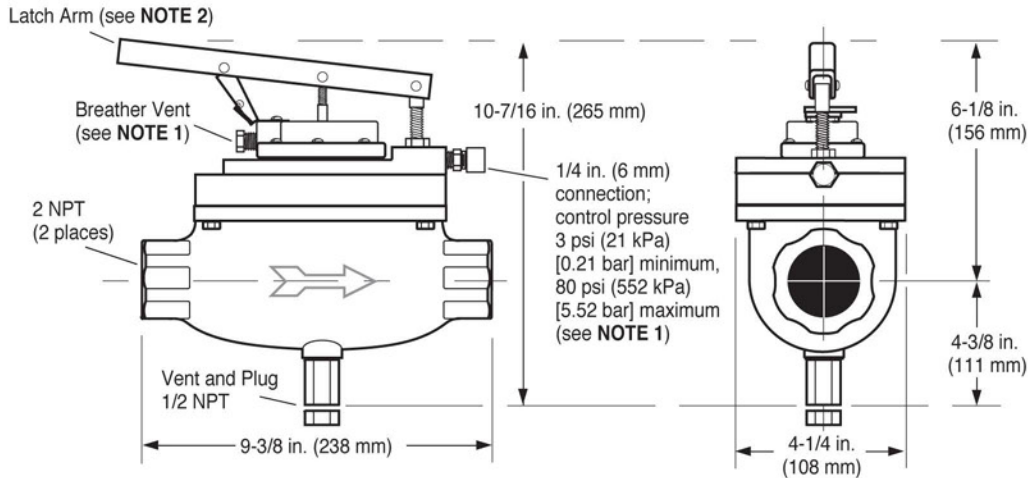

**NOTE 1:** Control pressure connection fitting and breather vent fitting can be swapped to convert to vacuum control.

**NOTE 2:** Thumb operated opening latch (2.5 psi [17 kPa] [0.17 bar] required to release cocking latch).

## Magnetic Switch Adapters

**65700053** (was 65020126); **65700054** (was 65020127); **65700055** (was 65020155)

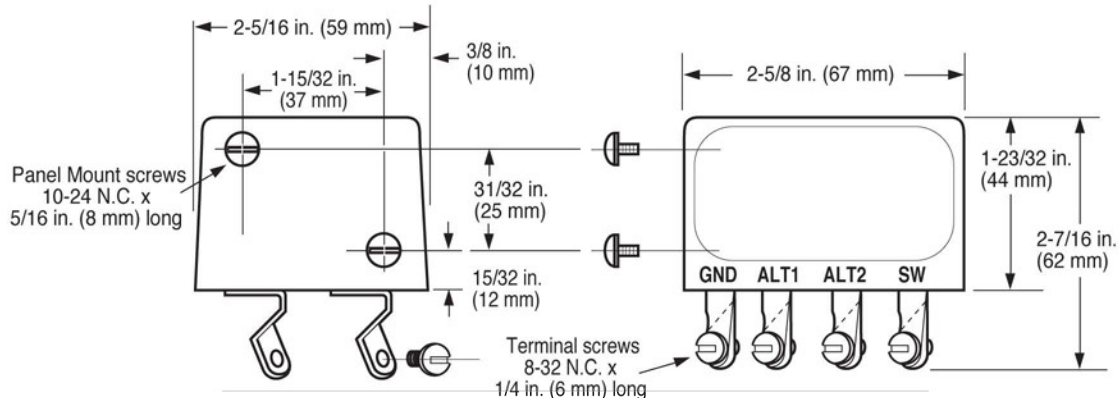





**CAUTION:** THE ARROW ON THE SIDE OF THE FUEL VALVE **MUST** POINT TO THE CORRECT DIRECTION OF THE FLOW, FROM FUEL SOURCE TO THE ENGINE. APPLY PIPE DOPE **ONLY** TO FUEL PIPE, **NOT** TO THE FUEL VALVE.

**M5081 and M5081FS**

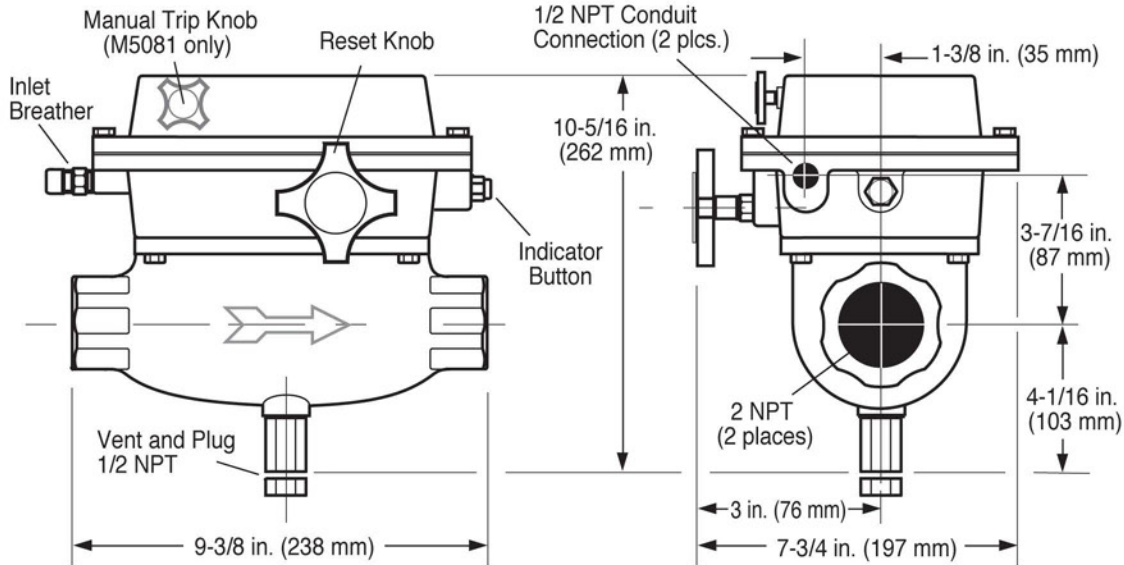

**M5081-3 Steel Flanged Option**

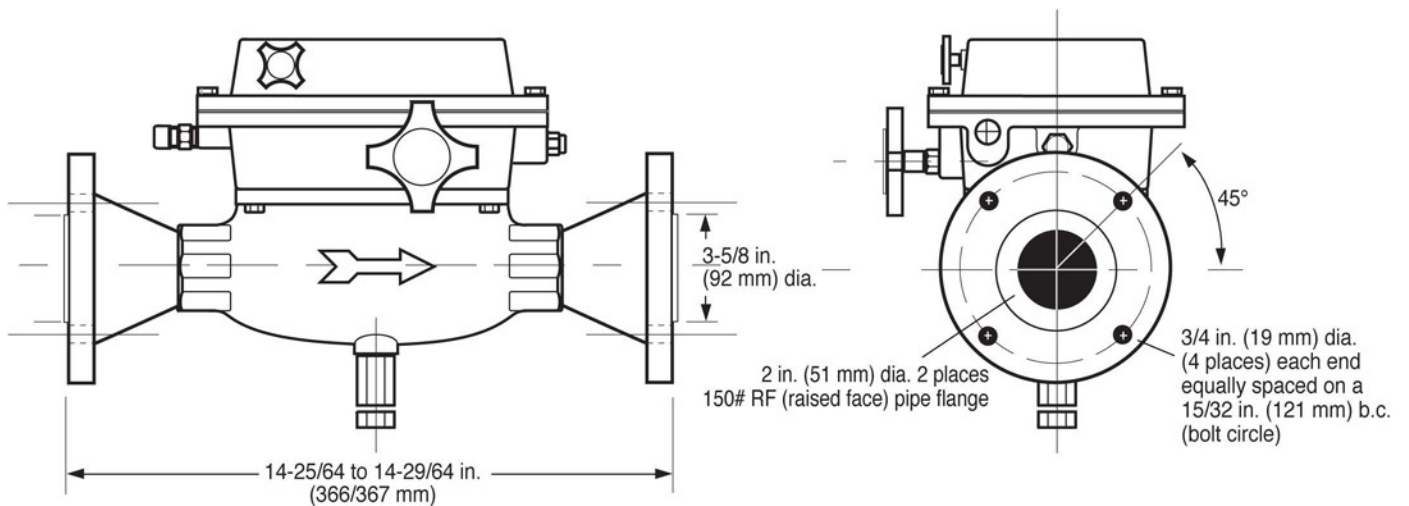

# INSTALLATION



**WARNING:** STOP THE ENGINE AND DISCONNECT ALL ELECTRICAL POWER BEFORE BEGINNING INSTALLATION. BEGIN THE INSTALLATION BY SECURING AREA OF ANY HAZARDOUS CONDITIONS. SHUTOFF THE FUEL GAS SUPPLY. FOR HAZARDOUS APPLICATIONS REFER TO NATIONAL ELECTRICAL CODE SPECIFICATIONS.

## Connecting the Fuel Shut-off Valve

1. Before connecting the unit, apply pipe dope to plumbing male threads that will be inserted into the valve. Do **not** apply pipe dope to the valve.
2. Make sure that the arrow on the side of the valve indicates the correct direction of the flow.
3. Fuel shut-off valves can be installed in all three planes. However, mounting the valve horizontally (with vent pointing down) is recommended. Do **not** install valve with top down. (Refer to **Figure 1**.)
4. Hold valve in position, (use a tool on valve wrench flats) and tighten plumbing into inlet and outlet ends. (Refer to dimensions on pages 3-4.)



**CAUTION:** DO NOT TWIST THE VALVE BODY HOUSING.

5. To mount flanged models, follow the appropriate installation codes and ordinances for the application. (For dimensions see page 4.)
6. A vent line (to allow gas trapped forward between fuel valve and the carburetor to escape) should be attached to the vent connection at the bottom of the valve housing. Remove the plug and install the line. (Refer to **Figure 1**.)

## Connecting Pneumatic Models M2582-P and M5180-P

1. Repeat the steps above (1 thru 5), and observe the necessary cautions.
2. A lever/arm (handle) and a cocking latch are provided to allow manual opening of the valve. The thumb-operated latch can be locked in place to hold the lever/arm latched. The cocking latch will be released when pilot pressure reaches 2.5 psi (17 kPa) [0.17 bar]. M2582-P and M5180-P automatically open at 2 psi (14 kPa) [0.14 bar], and fully open at 3 psi (21 kPa) [0.21 bar]. See Specifications, page 12 for



**CAUTION:** BE SURE PNEUMATIC SOURCE RELEASES THE MECHANICAL LATCH WHEN RUNNING.

maximum control pressure.

3. If vacuum control is desired, swap the Control Pressure connection fitting and the Breather Vent fitting on your M5180-P model (see **Fig. 2**).

**Figure 1**  
**Physical Location and Plumbing (typical)**

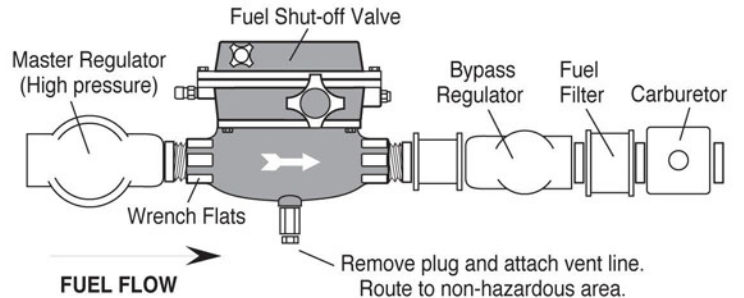

**Figure 2**  
**Pull the lever up, and press the latch down into ridge with thumb.**

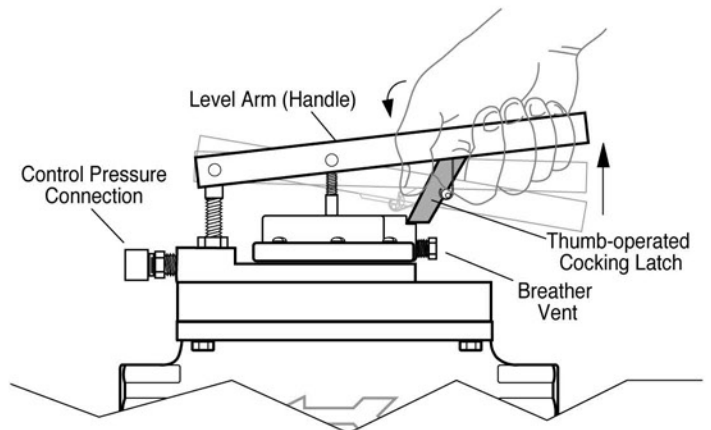

# WIRING INFORMATION



**WARNING:** PERFORM THE WIRING OPERATION WITH THE POWER SOURCE “OFF” AND THE AREA MADE NON-HAZARDOUS. MAKE SURE THE VOLTAGE AND CURRENT REQUIREMENTS ARE WITHIN THE FUEL SHUT-OFF VALVE RATINGS. HARD CONDUIT WITH APPROVED SEALS IS REQUIRED BY THE NEC FOR HAZARDOUS AREA INSTALLATIONS.

## M2582 Internal Wiring

Wiring shown in normal mode of operation (seat open). The 20 AWG (0.75 mm<sup>2</sup>) wire is color coded to the coil:

- For CD ignitions:* White and Orange
- For Magneto ignitions:* White and Green
- For Battery:* White and Blue

### Conduit Installation

Install a 1/2 NPT conduit from the M2582 conduit connection to the power source. See M2582 Dimensions (page 3) for location.

For wiring the M2582 fuel valve to Solid-State TATTLETALE® annunciators, refer to pages 9, 10, and 11.

## Internal Wiring for M2582

### NOTE:

For grounding the ignition (CD models only) through the fuel valve snap-switch, use a Magnetic Switch Adapter (see **Magnetic Switch Adapter**, below) and install a 100 ohm; 2 watt resistor (included on page 11).

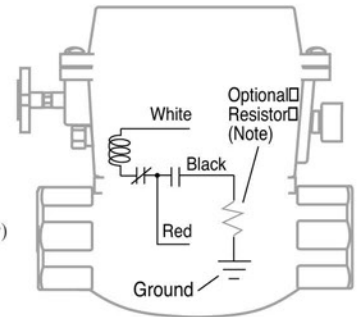

## M5081 Internal Wiring

Wiring shown in normal mode of operation (seat open). The 18 AWG (1.0 mm<sup>2</sup>) wire is color coded to the coil:

- For CD Ignitions:* White and Orange
- For Magneto Ignitions:* White and Green
- For Battery:* White and Blue

### Conduit Installation

Install a 1/2 NPT conduit from the M5081 conduit connection to the power source. Refer to Dimensions (on page 4) for location.

For typical wiring of the M5081 models refer to pages 7 and 8.

For wiring the M5081 fuel valves to Solid-State TATTLETALE® annunciators, refer to pages 9, 10, and 11.

## M5081 Internal Wiring

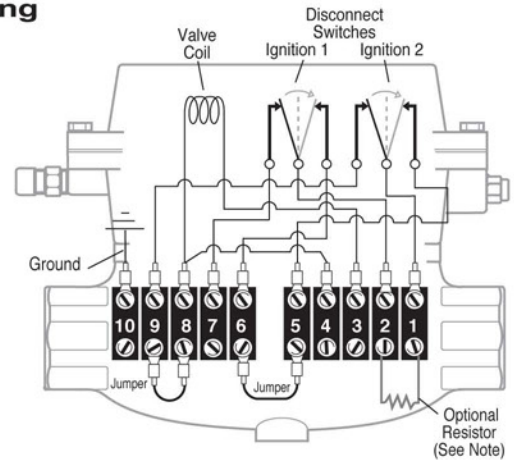

**NOTE:** For grounding the ignition (CD models only) through the fuel valve snap-switches, use a Magnetic Switch Adapter, see **Magnetic Switch Adapter**, below and the “TO CLOSE THE FUEL VALVE and GROUND THE IGNITION” attachment, and install a 100 ohm; 2 watt resistor (included with your attachment).

## M2582-C-LS Wiring

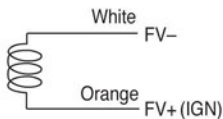

## M5081-C-LS Wiring

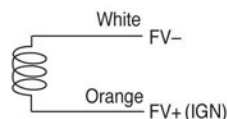

## M5081FS Internal Wiring

For typical Wiring refer to page 8.

For wiring the M5081FS to MARK IV 12/24 refer to page 10.

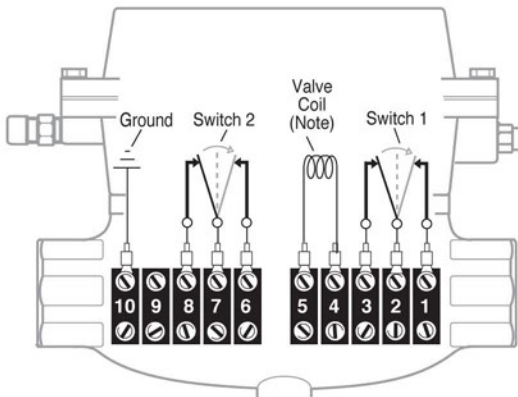

**NOTE:** Wiring shown in normal mode of operation (seat open). The 18 AWG (1.0 mm<sup>2</sup>) wire is red color for both options: 12 VDC and 24 VDC.

## Magnetic Switch Adapters for Use with Capacitor Discharge Ignitions

Connect the Magnetic Switch Adapter between the fuel Valve terminal 1 and the CD Ignition. See wiring diagrams (pages 7 and 11).

65700053 (was 65020126): For use with negative ground ignitions up to 240 VDC.

65700054 (was 65020127): For use with positive ground ignitions up to 450 VDC.

65700055 (was 65020155): For use with negative ground ignitions up to 450 VDC.

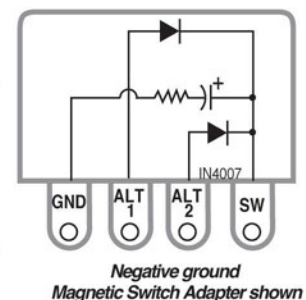



## TYPICAL WIRING for M5081-C (CD IGNITION MODELS)

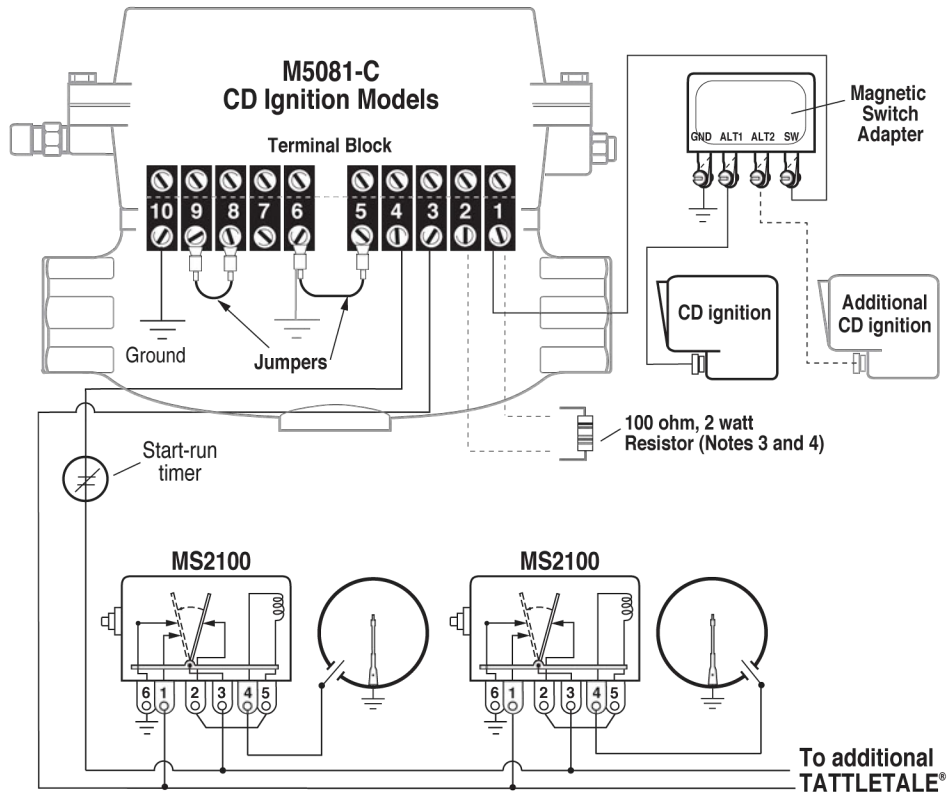

- NOTE 1:** To CLOSE FUEL VALVE—NOT GROUNDING THE IGNITION (Single CD Ignition Systems) Remove the factory-installed jumper on terminals 6-5. Do NOT ground terminal 6.
- NOTE 2:** To CLOSE FUEL VALVE—NOT GROUNDING THE IGNITIONS (Dual CD Ignition Systems) Remove the jumper on terminals 6-5. Connect second ignition to Magnetic Switch Adapter terminal ALT2.
- NOTE 3:** To CLOSE FUEL VALVE and GROUND THE IGNITION (Single CD Ignition Systems) Remove the jumper on terminals 6-5. Connect a 100 ohm, 2 watt resistor between valve terminals 1-2. Ground terminal 6.
- NOTE 4:** To CLOSE FUEL VALVE and GROUND THE IGNITION (Dual CD Ignition Systems) Remove the jumper on terminals 6-5. Connect a 100 ohm, 2 watt resistor between valve terminals 1-2. Ground terminal 6. Connect second ignition to Magnetic Switch Adapter terminal ALT2.

## TYPICAL WIRING for M5081-B (BATTERY IGNITION MODELS)

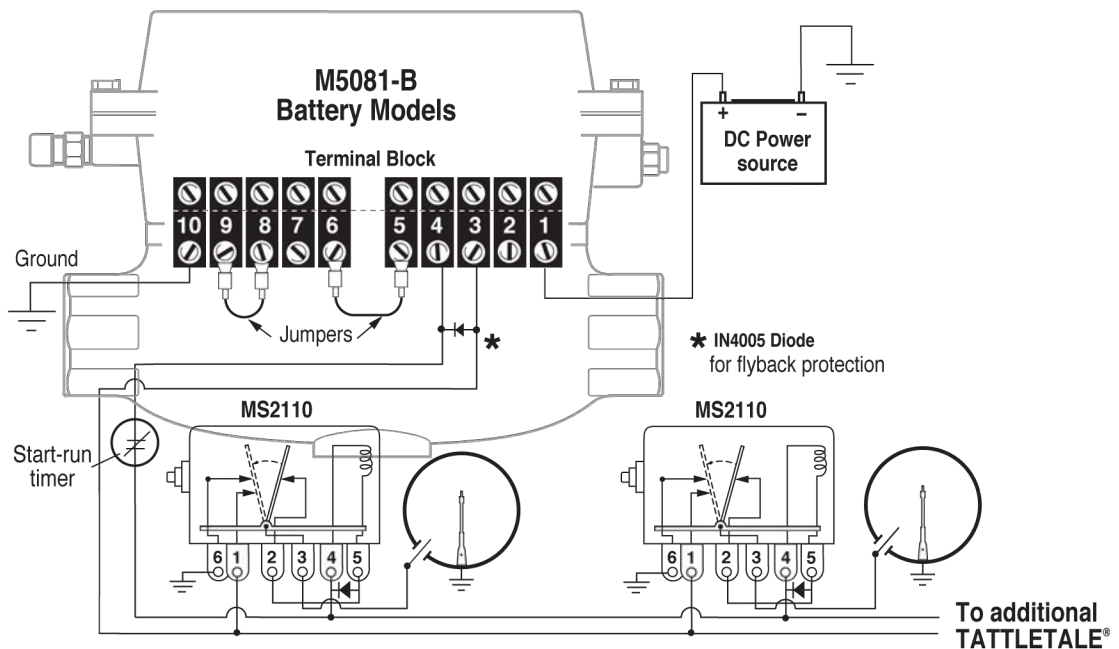

# TYPICAL WIRING for M5081-A (MAGNETO IGNITION MODELS)

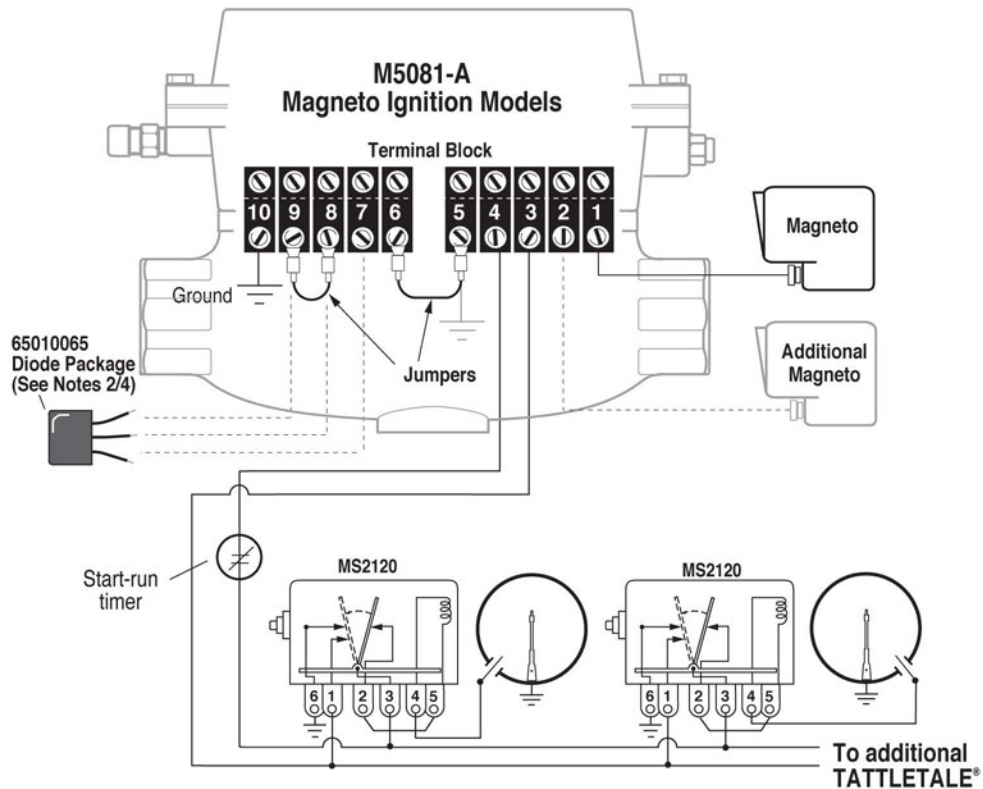

- NOTE 1:** To CLOSE FUEL VALVE—NOT GROUNDING THE IGNITION (Single Magneto Systems) Remove the factory-installed jumper on terminals 6-5. Do NOT ground terminal 5.
- NOTE 2:** To CLOSE FUEL VALVE—NOT GROUNDING THE IGNITIONS (Dual Magneto Systems) Remove the factory-installed jumpers on terminals 6-5 and 9-8. Add 65010065 diode package as shown. Do NOT ground terminals.
- NOTE 3:** To CLOSE FUEL VALVE and GROUND THE IGNITION (Single Magneto Systems) The factory-installed jumpers (6-5 and 9-8) must be in place. Add ground wire to terminal 5.
- NOTE 4:** To CLOSE FUEL VALVE and GROUND THE IGNITION (Dual Magneto Systems) Remove the jumper on terminals 9-8. Add 65010065 diode package as shown. Add ground wire to terminal 5.

# TYPICAL WIRING for M5081FS (NORMALLY ENERGIZED MODELS)

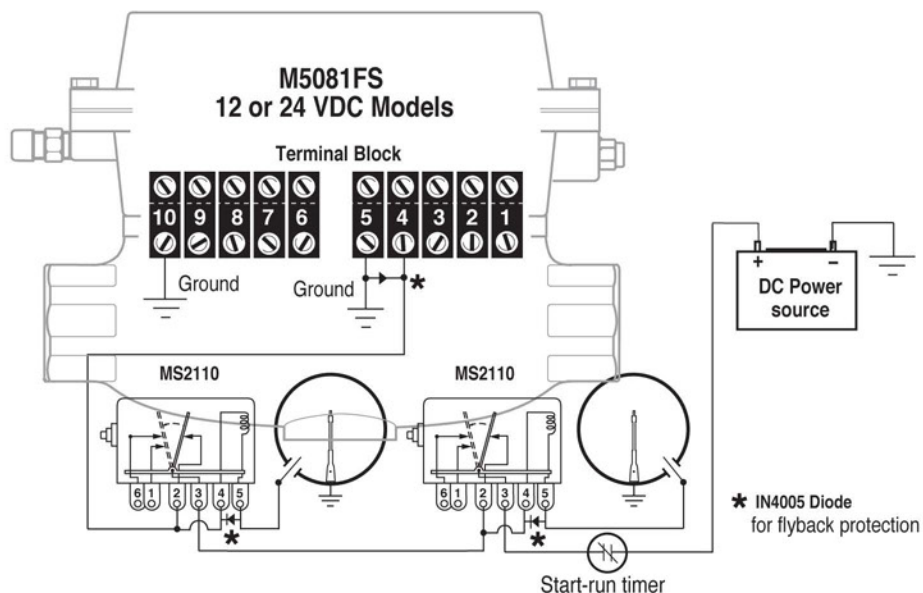



# TYPICAL WIRING to SOLID-STATE TATTLETALE® Annunciators



**WARNING:** PERFORM THE WIRING OPERATION WITH THE POWER SOURCE “OFF” AND THE AREA MADE NON-HAZARDOUS. MAKE SURE THE VOLTAGE AND CURRENT REQUIREMENTS ARE WITHIN THE FUEL SHUT-OFF VALVE RATINGS. HARD CONDUIT WITH APPROVED SEALS IS REQUIRED BY THE NEC FOR HAZARDOUS AREA INSTALLATIONS.

## M2582-C to LCDT-PS-CD (R)-P (positive ground)

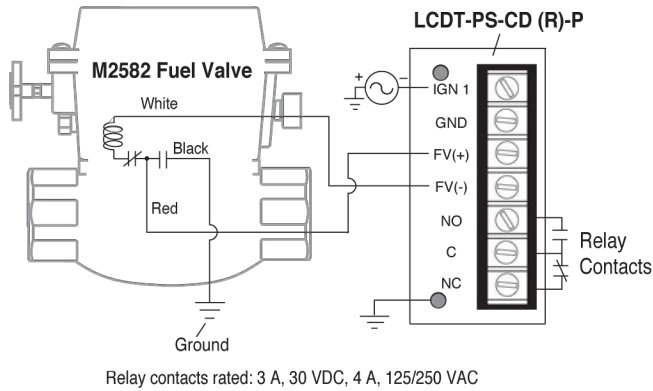

## M5081-C to LCDT-PS-CD (R)-P (positive ground)

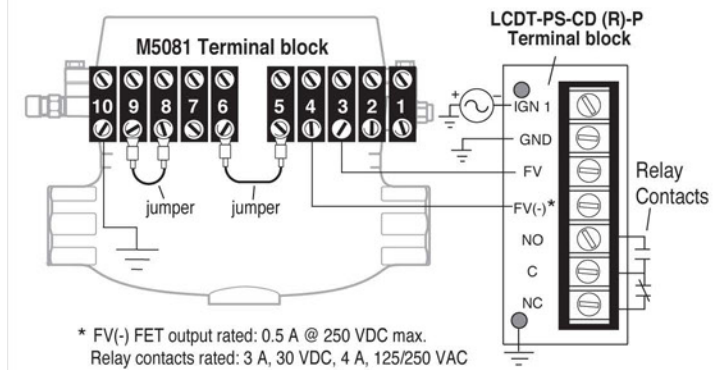

## M2582-C to LCDT-PS-CD-N (negative ground)

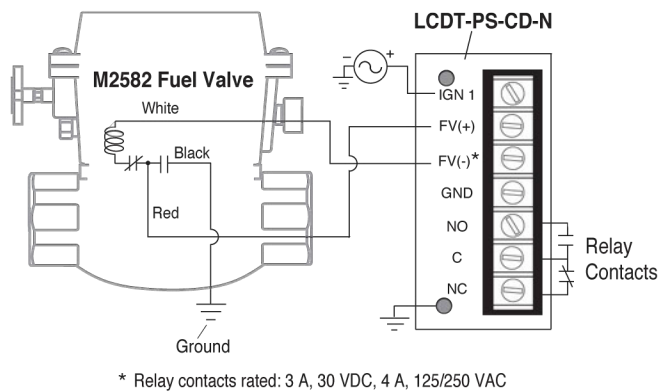

## M5081-C to LCDT-PS-CD-N (negative ground)

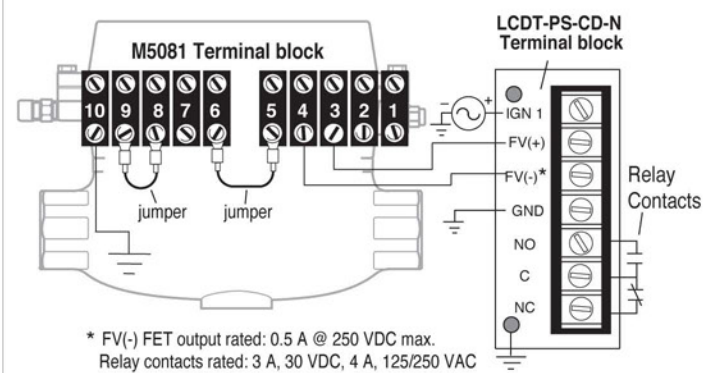

## M2582-C to MARK IV-N (negative ground)

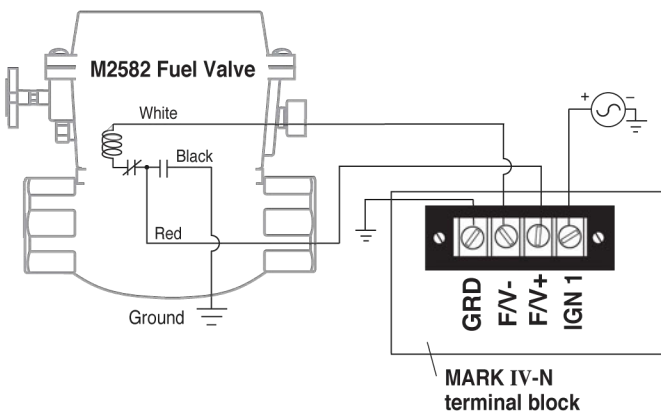

## M5081-C to MARK IV-N (negative ground)

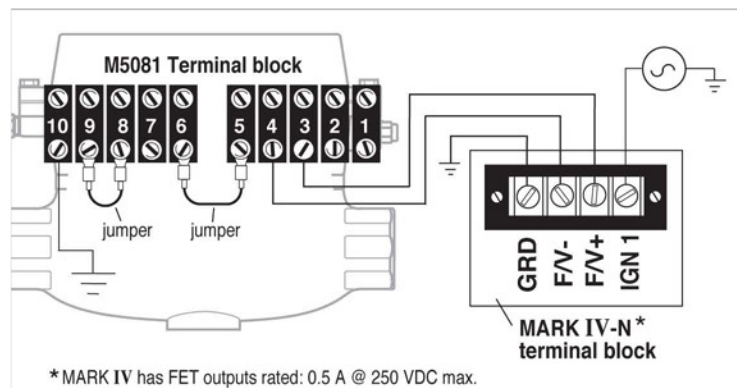

# TYPICAL WIRING to SOLID-STATE TATTLETALE® Annunciators



**WARNING:** PERFORM THE WIRING OPERATION WITH THE POWER SOURCE “OFF” AND THE AREA MADE NON-HAZARDOUS. MAKE SURE THE VOLTAGE AND CURRENT REQUIREMENTS ARE WITHIN THE FUEL SHUT-OFF VALVE RATINGS. HARD CONDUIT WITH APPROVED SEALS IS REQUIRED BY THE NEC FOR HAZARDOUS AREA INSTALLATIONS.

## M5081FS to MARK IV-12/24

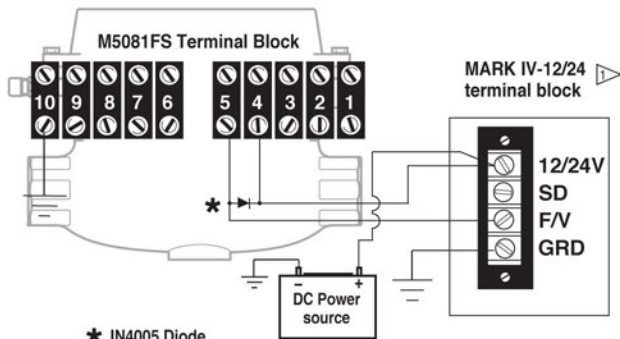

\* IN4005 Diode for flyback protection

▷ MARK IV has FET outputs rated: 0.5 A @ 250 VDC max.

## M5081-B to MARK IV-12/24

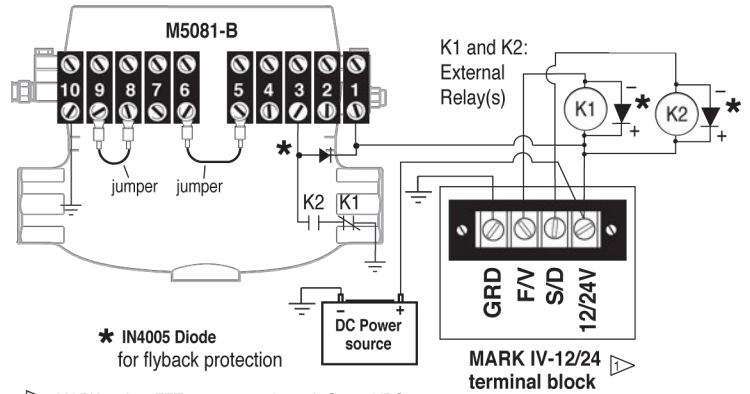

\* IN4005 Diode for flyback protection

▷ MARK IV has FET outputs rated: 0.5 A @ 250 VDC max. Remove shunt jumper E2 for ignition ground time delay.

## M5081FS to MARK III-12/24

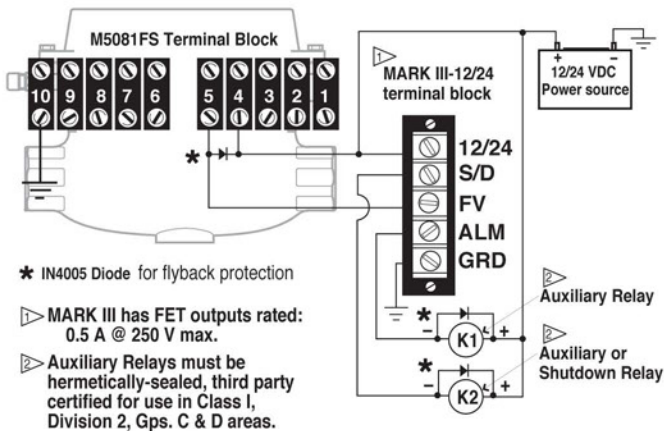

\* IN4005 Diode for flyback protection

▷ MARK III has FET outputs rated: 0.5 A @ 250 V max.

▷ Auxiliary Relays must be hermetically-sealed, third party certified for use in Class I, Division 2, Gps. C & D areas.

## M5081-C to MARK III-N

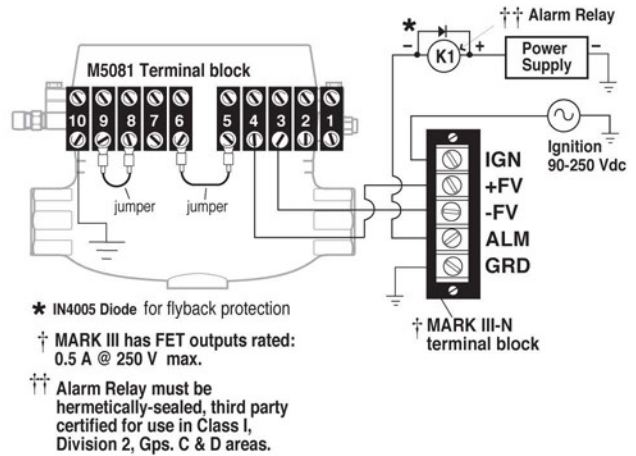

\* IN4005 Diode for flyback protection

† MARK III has FET outputs rated: 0.5 A @ 250 V max.

†† Alarm Relay must be hermetically-sealed, third party certified for use in Class I, Division 2, Gps. C & D areas.

## M5081-C to TTDJ-IGN-(T)

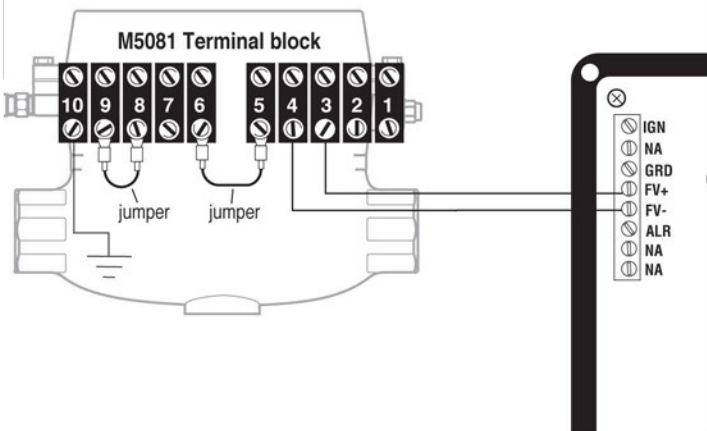

## M2582-C to TTDJ-IGN-(T)

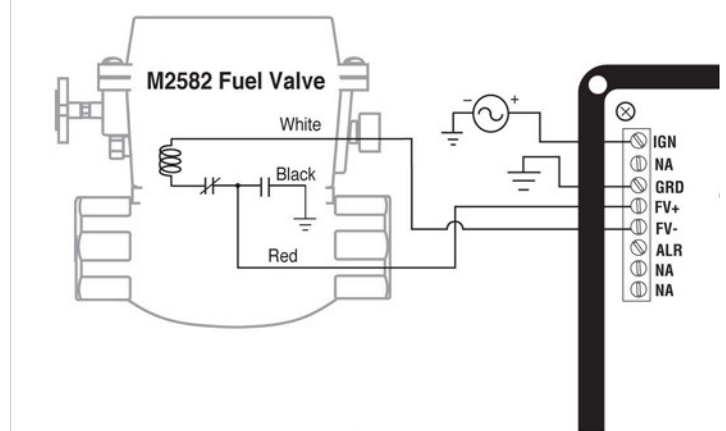



**WARNING:** PERFORM THE WIRING OPERATION WITH THE POWER SOURCE "OFF" AND THE AREA MADE NON-HAZARDOUS. MAKE SURE THE VOLTAGE AND CURRENT REQUIREMENTS ARE WITHIN THE FUEL SHUT-OFF VALVE RATINGS. HARD CONDUIT WITH APPROVED SEALS IS REQUIRED BY THE NEC FOR HAZARDOUS AREA INSTALLATIONS.

**(A) M5081-B to TTDJ-DC-(T)**

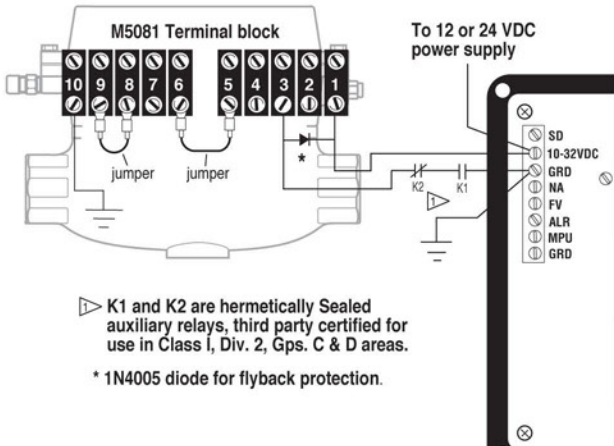

**(B) M2582-B to TTDJ-DC-(T)**

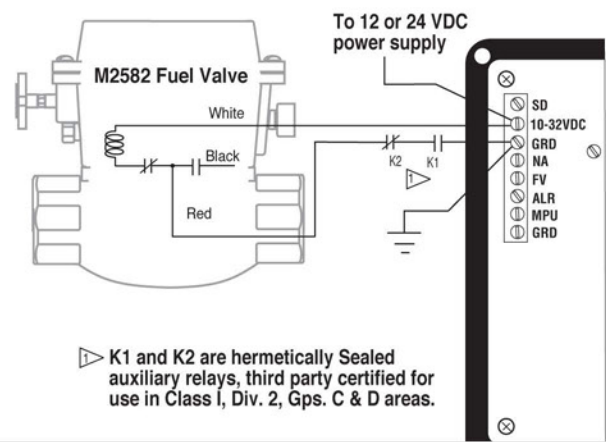

**TTDJ-DC-(T) to Relays**

Connections Shown for Use with Diagrams (A), (B), (C), and (D) on this page.

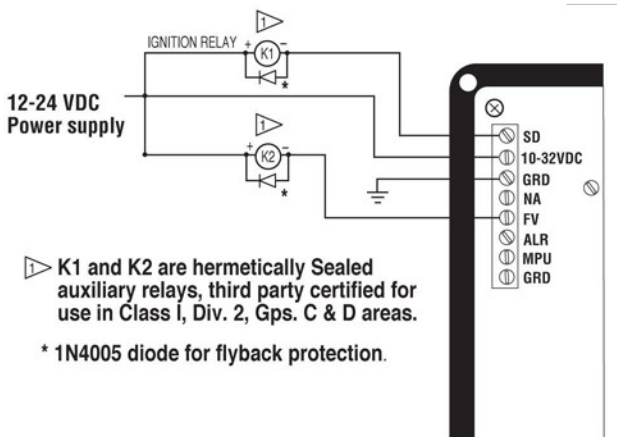

**M5081FS to TTDJ-DC-(T)**

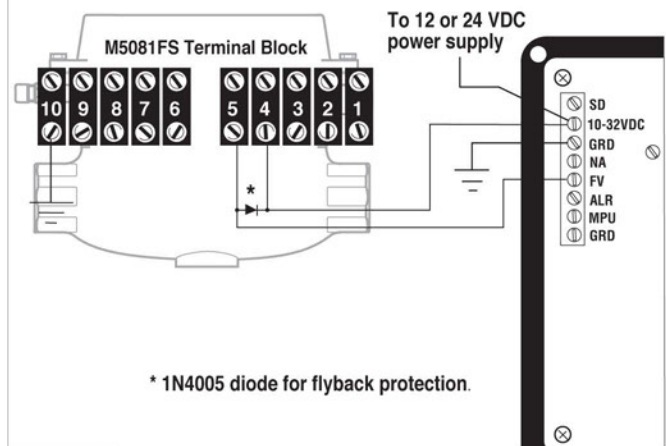

**(C) M2582-C w/Magnetic Switch Adaptor to CD Ignition**

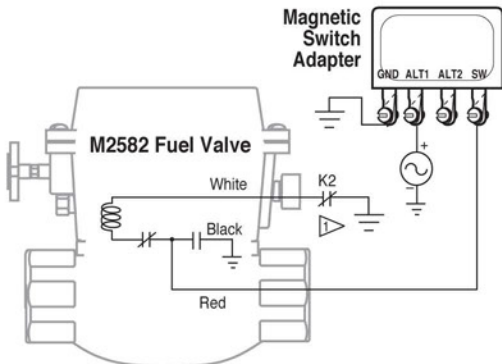

**(D) M5081-C w/Magnetic Switch Adaptor to CD Ignition**

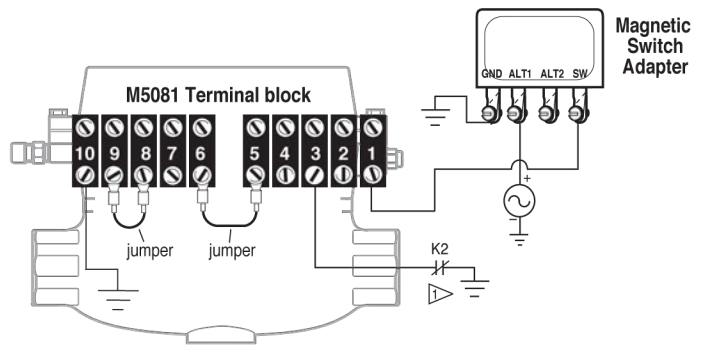



**Valve Body:** Sandcast aluminum, painted red (corrosion resistance);  
*Optional cast steel available for M5081 and M5081FS models only.*

**Valve Seat:** Buna-

**Maximum Valve Inlet Pressure:**

- M2582/M2582-P: 80 psi (552 kPa) [5.52 bar]
- M5081/M5081FS/ 5180-P: 100 psi (689 kPa) [6.89]

**Maximum Control Pressure (Pneumatic Models):**

- M2582-P: 75 psi (517 kPa) [5.17 bar]
- M5180-P: 80 psi (552 kPa) [5.52 bar]

**Snap-switch:** M2582: *One SPDT, 5 A @ 480 VAC*  
 M5081, and M5081FS: *Two SPDT, 5 A @ 480 VAC*

**Wiring:** M2582: *Wire leads*; M5081, and M5081FS: *Terminal blocks*

**NOTE:** *All aluminum versions of the M5081 Series Fuel Valve carry Canadian Registration Number OC1476.2.*

**Coil Rating:** Intermittent duty; coil type must match power source;

- CD ignition coil resistance: 72 Ω  
 CD ignition primary voltage: 1.38 to 3.8 A
- M5081FS: Energized to Run (continuous-duty coil) coil resistance:  
 12 V model: 33 Ω;  
 24 V model: 136 Ω
- Magneto ignition coil resistance: 0.5 Ω  
 agneto primary voltage: 1 to 5 A
- Battery coil resistance : 7 Ω  
 12 or 24 VDC: 1.2 to 2.4 A

**Laboratory Approval:** CSA li ted for Cla I, Group C and D  
 Hazardou Location .5 amp maximum; intermittent duty; model  
 M5081 and M5081-CD engine ignition powered, and model M5081-B, 12  
 or 24 VAC or VDC; switch contacts rated 5 A @ 480 VAC maximum.  
 Maximum pressure 100 psi (689 kPa) [6.89 bar].

**SERVICE PARTS**

	<b>M2582</b>	<b>M5081</b>	<b>M5081FS</b>	<b>M2582-P</b>	<b>M5180-P</b>
<b>Coil Assembl</b>					
Batte	55000128	55000126	-----	-----	-----
CD Ignition	55000129	55000127	-----	-----	-----
Magneto Ignition	55000094	55000080	-----	-----	-----
<b>M5081FS Coil Assembly</b>					
12 VDC	-----	-----	55000158	-----	-----
24 VDC	-----	-----	55000159	-----	-----
<b>Latch Block Assembly</b>					
Latch block assembl	55000095	55000074	-----	-----	-----
Latch block switch and coil assembl	-----	-----	-----	-----	-----
Latch block switch and mounting bracket assembly	-----	55000118	55000196	-----	-----
<b>Handle and Latch Kit</b>					
Handle and latch kit	-----	55000102	55000102	5500148	55000154
Handle kit	55000096	-----	-----	-----	-----
<b>Manual Disconnect Assembly</b>					
Manual Disconnect Assembly	55000097	55000137	-----	-----	-----
<b>Snap Switch Assembly</b>					
Snap Switch Assembly	55000098	55000072	55000160	-----	-----
<b>Close/Open Indicator Assembly</b>					
Close/Open Indicator Assembly	-----	55000138	55000138	-----	-----
<b>Stem and Seat Kit</b>					
Stem and Seat Kit	55000093	55000075	55000135	55000147	55000135
<b>Top Works Complete Valve Less Body and Vent</b>					
Top Works Complete Valve Less Body and Vent	55000146	55000131	55000161	55000150	55000155
<b>Vent Bushing Assembly</b>					
Vent Bushing Assembly	55000143	55000132	55000132	55000143	55000132
<b>Diaphragm Assembly</b>					
Diaphragm Assembly	-----	-----	-----	55000184	55000153
<b>Pilot Diaphragm</b>					
Pilot Diaphragm	-----	-----	-----	00007908	55050420
<b>Diode Package for Dual Magneto Ignitions</b>					
Diode Package for Dual Magneto Ignitions	-----	65010065	-----	-----	-----
<b>Magnetic Switch Adapter for CDI Ignitions</b>					
Single/Dual ign. – negative ground up to 240 VDC	65700053	65700053	-----	-----	-----
Single/Dual ign. – positive ground up to 450 VDC	65700054	65700054	-----	-----	-----
Single/Dual ign. – negative ground up to 450 VDC	65700055	65700055	-----	-----	-----

**Warranty**

A limited warranty on materials and workmanship is given with this FW Murphy product.  
 A copy of the warranty may be viewed or printed by going to [www.fwmurphy.com/support/warranty.htm](http://www.fwmurphy.com/support/warranty.htm)

**FW MURPHY PRODUCTION CONTROLS**

SALES, SERVICES & ACCOUNTING  
 5417 S. 122ND E. AVE.  
 TULSA, OK 74146

CONTROL SYSTEMS & SERVICES  
 105 RANDON DYER ROAD  
 ROSENBERG, TX 77471

MANUFACTURING  
 5757 FARINON DRIVE  
 SAN ANTONIO, TX 78249

**DOMESTIC SALES & SUPPORT**

FW MURPHY PRODUCTS  
 PHONE: 918 317 4100  
 EMAIL: [INFO@FWMURPHY.COM](mailto:INFO@FWMURPHY.COM)  
[WWW.FWMURPHY.COM](http://WWW.FWMURPHY.COM)

FW MURPHY CONTROL SYSTEMS & SERVICES  
 PHONE: 281 633 4500  
 EMAIL: [CSS-SOLUTIONS@FWMURPHY.COM](mailto:CSS-SOLUTIONS@FWMURPHY.COM)

**INTERNATIONAL SALES & SUPPORT**

CHINA  
 PHONE: +86 571 8788 6060  
 EMAIL: [APSALES@FWMURPHY.COM](mailto:APSALES@FWMURPHY.COM)

LATIN AMERICA & CARIBBEAN  
 PHONE: +1 918 317 2500  
 EMAIL: [LASALES@FWMURPHY.COM](mailto:LASALES@FWMURPHY.COM)

SOUTH KOREA  
 PHONE: +82 70 7951 4100  
 EMAIL: [SKOREASALES@FWMURPHY.COM](mailto:SKOREASALES@FWMURPHY.COM)



FM 620667 (San Antonio, TX - USA)  
 FM 668933 (Rosenberg, TX - USA)



FM 523851 (China) TS 589322 (China)